

The Valve Gear Club

DRIVING THE P2 TO BECOME BRITAIN'S MOST
POWERFUL STEAM LOCOMOTIVE

Over
£4.5m
raised of
the £6m needed
to complete the P2



Follow us on:



Join today to help us manufacture the valve gear
for Gresley Class P2 2-8-2 No. 2007 *Prince of Wales*



2007 PRINCE OF WALES

Building Britain's Most Powerful Steam Locomotive



We are building a brand new P2 class steam locomotive, based on the original 1930s design, and developed for use on the modern rail network.

The project to build P2 No. 2007 *Prince of Wales* launched in 2013 and has made significant progress. £4.5 million has already been raised, with most large components now manufactured, from the boiler to the tender.

The Gresley class P2 'Mikados' were the most powerful express passenger locomotives to operate in the UK. They were designed by Sir Nigel Gresley to haul 600-ton trains over the arduous Edinburgh to Aberdeen route.

The ultimate performance and economy of a steam locomotive is dependent on optimising the complete thermal system from the fire hole door to the top of the chimney. Assuming the boiler and smoke box are fundamentally sound, the most important areas for good design are the cylinders and valves.

The design and manufacture of the unique cylinder monobloc, delivered to Darlington

Locomotive Works in autumn 2023, was the first step towards building the powerhouse of the P2. With that work complete, we turn our attention to the other side of that same coin: the valve gear.

Lentz poppet valve gear is a more efficient design than Walschaerts valve gear, which is commonly found on UK locomotives including *Tornado*. Lentz developed the concept by which an improved system of large passages, large areas through valves and suitably controlled valve events, would fully utilise the latent capacity of the boiler. Lentz poppet valve gear was fitted on the first P2, No. 2001 *Cock o' the North*, and we will be taking this principle and applying it to the valve gear design for No. 2007.

For manufacture and testing of the new design, we need to raise £300,000 - the first £50,000 of which will immediately go towards the building of a prototype and test rig. The Valve Gear Club seeks to raise these funds through donations of £1000, in a lump sum or smaller instalments.

History of Lentz Poppet Valve Gear



No. 2001 *Cock o' the North*

- Poppet valve gear was initially developed in 1907 as oscillating type driven by Stephenson or Walschaerts valve gear.
- First rotary cam (RC) valve gear developed in 1928 – fitted to six D49 engines. These had stepped cams providing a limited number of cut-offs.
- First application of continuously variable gear on the first P2 class locomotive, No. 2001 in 1934.
- No. 2001 reverted to stepped cams at end of 1934.

Lentz Valve Gear and the P2 Class

By keeping true to the valve gear design of No. 2001 and adapting that design to incorporate post war developments, we are able to harness the potential efficiencies and additional power envisaged by Sir Nigel Gresley.

In 1907, Dr Hugo Lentz developed a form of poppet valves where the cams of the oscillating type were driven by conventional Walschaerts or Stephenson valve gear. The original Lentz design was developed to be driven by rotary cams, which in turn take their drive through gear boxes and cardan shafts from the locomotive's wheels. This design was successfully applied to several hundred locomotives worldwide. Poppet valves are also used in internal combustion engines and are activated by cams.

The first P2 class locomotive No. 2001 *Cock o' the North* was fitted with Lentz rotary cam poppet valves. This was unusual as most modern steam locomotives used piston valves, where the entry of live steam to and the exit of exhaust steam from the cylinders was controlled with piston valves driven backwards and forwards by the valve gear. On RC valve gear, the live and exhaust steam cut offs can be adjusted independently. Gresley recognised that poppet valves can result

in higher power, greater efficiency, and reduced maintenance.

The first application of continuously variable gear was on No. 2001 in 1934. When proposed for No. 2001, Gresley requested that the Associated Locomotive Equipment Company provided continuously variable cams, rather than stepped cams, thus providing an infinite number of settings between 10% and 75% cut-off. This fine adjustment was required with powerful locomotives and will enable economical operation of No. 2007

However, on No. 2001 the continuous cams wore rapidly and required replacement after only 10,000 miles, so stepped cams were fitted, adversely affecting its economy. Fortunately for No. 2007 *Prince of Wales*, the Lentz valve gear was further developed by the Franklin company of the USA during the 1940s which overcame the wear problems with the cams and other maintenance issues.

Lentz-Franklin Valve Gear

The Franklin Company in the USA took on the Lentz patents in the early 1940s and they did what the Americans do best – develop and productionise a basic idea. Metal hardening methods developed through WW2 overcame the grooving problems in early continuous cams, and most components were "beefed up". Additionally, the cam slider mechanism changed from rack and pinion to screw operation resulting in less backlash which, more importantly, cannot back feed into the reverser.



Under Vernon Smith, the Franklin version of Lentz gear with infinitely variable cams were fitted to the K4S.

The original P2s and the new P2 design

We have been fortunate to obtain details of the Franklin developments and have incorporated these into the design of the valves and valve gear for No. 2007, (including copies of the original blueprints of the Santa Fe 3752 - photo on page 3). Combined with modern design software and modelling, we have been able to bring the Lentz-Franklin valve gear into the 21st Century, specifically adapted for the new P2.

The arrangement of the valves around the three cylinders, with the middle cylinder raised, created an engineering dilemma which was never satisfactorily resolved – until now! Gresley's solution was to have inlet and exhaust valves on opposite sides inside cylinder. This resulted in very large and uneven clearance volume resulting in lost cylinder efficiency. The live and exhaust steam pipes sat next to each other, only separated by a steel wall, causing massive heat transfer – as much as 100°F recorded in tests at Vitry.

The alterations made in the Elliott design solve two significant weaknesses in the original P2 valve gear design.

1. The clearance volumes are now the same for each cylinder
2. The live steam inlets are away from the exhaust steam pipes, reducing inefficiencies caused by significant heat transfer.

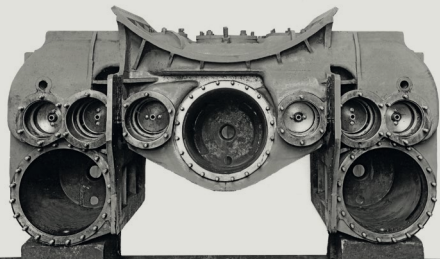

The original monobloc cast iron cylinder block for No. 2001 *Cock o' the North* (front view).

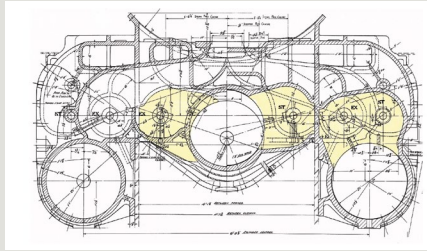

No. 2001 Clearance Volumes

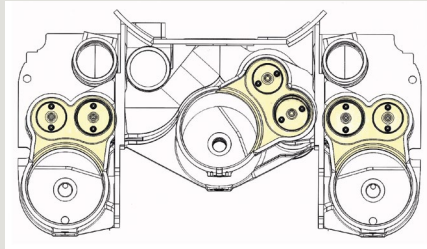

No. 2007 Solution - David Elliott's monobloc design deals with these issues most elegantly.

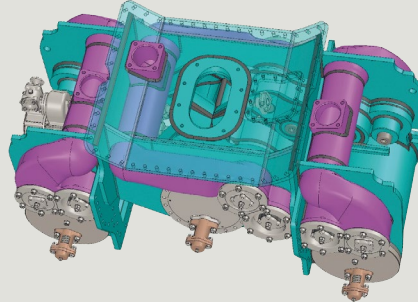

The position of the valves led to a final technical challenge: transferring drive from right hand cam box inside inlet cams to the valves. The design solution is to use rocking shafts, as illustrated on page 5. The rocking shaft will need to be strong, light and tolerant of high temperatures, so is likely to be a titanium structure.

WE ARE EFFECTIVELY UNTHROTTLING THE CYLINDERS!

Valve Gear: Walschaerts vs Lentz

	Walschaerts	Lentz
Economy	✓ Walschaerts very highly developed and capable of providing good economy if designed correctly.	✓ Rotary Cam valve gear has separate exhaust and inlet valves with separate cams to operate them, hence timing of inlet and exhaust is independent.
Efficiency	✗ Piston valve efficiency (sealing) degrades with wear	✓ Poppet valves remain steam tight longer between maintenance intervention.
Operation	✗ Limitation of Walschaerts is that both steam and exhaust are controlled by the same valve event.	✓ Poppet valves offer less friction in operation and absorb less power.
Power	Ordinary valve gear and piston rods at high speeds absorb as much as 200-300hp to drive them.	The Franklin-Lentz Gear at 500rpm of 80" wheels require only 3.3hp!

A1 vs P2 (sq. in)

	A1	P2	
Steam valve opening at max cut off	34.19	42.89	Fully open 8" inlet valve
Exhaust valve chest to cylinder port	33	55.02	Fully open 9" exhaust valve

This results in increased efficiencies, and greater potential horsepower. The P2 will be able to consistently produce over 2500hp at the drawbar, with over 3000hp at the cylinders, when climbing hard or at higher speeds. This would be in addition to improved economy at lower speeds and when minimal power is required.

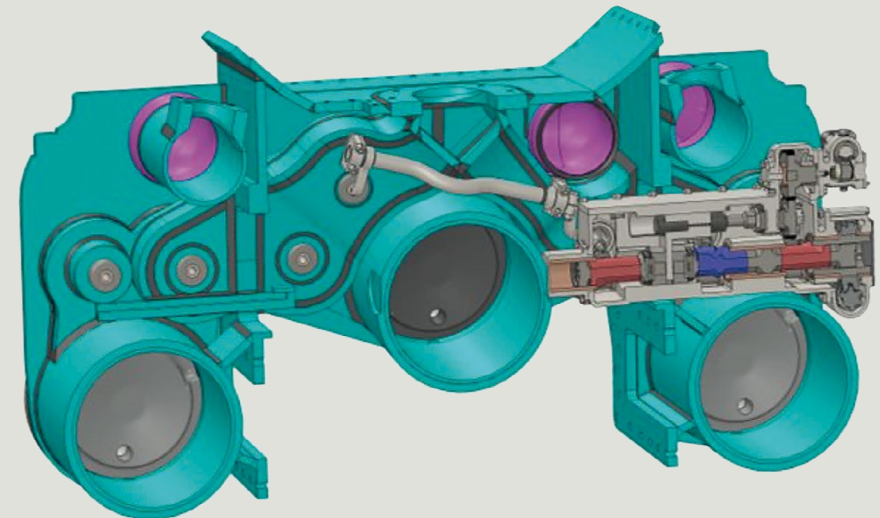

Cam box design for the middle cylinder.

To become a member of The Valve Gear Club, please complete the form at back of leaflet or email enquiries@p2steam.com, call 01325 460163 or visit www.p2steam.com for more information.

From the builders of No. 60163 Tornado – the first new main line steam locomotive built in Britain since 1960

Cam box design

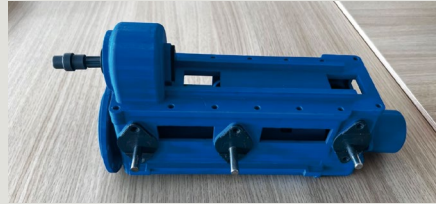
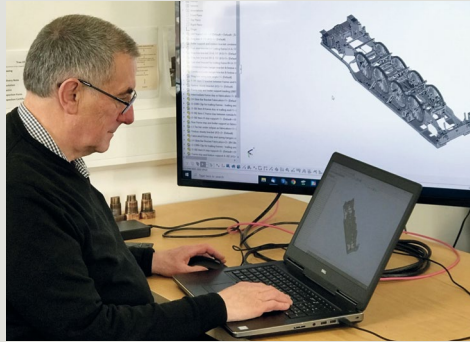

3D printed cam box at DLW.
David Elliott used 3D CAD to design many elements of the P2, a facility unavailable to the likes of Sir Nigel Gresley!

Prototype and Manufacturing:

The design schematic for the valve gear is complete. Manufacturing drawings are now underway, and the next step is to produce a prototype and test rig to prove the design. The test rig will have loads applied and run for fatigue, replicating the forces anticipated when in use on the locomotive. Given the rapid application and removal, the use of hydraulic cylinders will replicate the load. Once proven, the prototype will be fitted to the locomotive for use on *Prince of Wales*, and the subsequent cam box will be manufactured. The test rig will be set up at Darlington Locomotive Works.

The valve gear design for No. 2007 set out to address the historic shortcomings found on No. 2001 in the following ways:

Avoiding mechanical failure of components

- Use of CAD and FEA design
- Manufacture using high strength materials
- Manufacture of a fatigue rig to test

Other Mitigations:

- > Compared with Walschaerts gear, most components are contained within casings which will reduce risk of the locomotive shedding parts

- > Shear pins will be fitted in drive to cardan shafts to prevent over-torquing in seizure conditions
- > Locomotive will lose power in event of valve gear failure

Preventing inferior performance

- Use computer modelling - full thermal and fluid dynamic model to optimise valve events and reduce alterations in service
- Development and adjustment during trials

Stopping lubrication failure

- Mechanical multi-channel lubrication
- Correct choice of oil
- Oil cooling

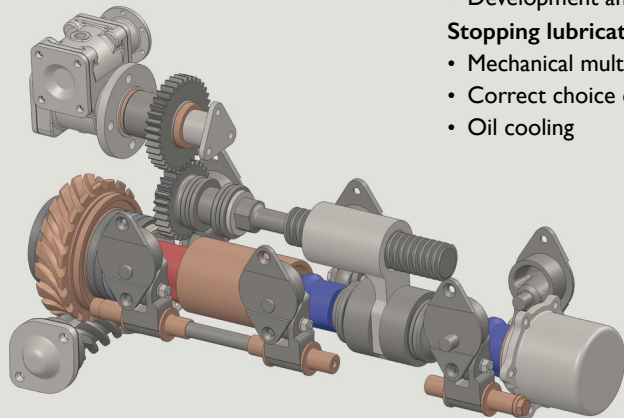

Cam shaft design.

Yes! I would like to support the P2 Project and join The Valve Gear Club

Sign up on our website at: www.a1steam.com/p2valvegear (or scan QR code)



Alternatively, please complete the form below and return to:

The A1 Steam Locomotive Trust
Darlington Locomotive Works,
9 Bonomi Way, Darlington, DL3 0PY.

Why not visit Darlington Locomotive Works and see No 2007 *Prince of Wales* under construction for yourself? We are open 10:00hrs to 15:00hrs on the first and third Saturday each month.

THE VALVE GEAR CLUB APPLICATION FORM

Name

Address

..... Post Code

Email Telephone

- I have enclosed a cheque for £1,000 made payable to "A1SLT – P2 Construction Fund" or
- I would like to make ten (10) payments of £100

To set up a Standing Order, please complete the following:

Bank / Address

..... Postcode

Dear Sir/ Madam

Please pay monthly on the 10th of each month, the sum of £....., commencing with the first payment on the 10th of (month)..... 202__, to the Yorkshire Bank Plc, Sort Code 05-09-36, for the credit of 'The A1 Steam Locomotive Trust' (a/c 19525055) and charge my account no. _ _ _ _ _ and sort code _ _ - _ _ - _ _

This order is in addition to any existing order that is in favour of 'The A1 Steam Locomotive Trust'.

Yours faithfully,

Signature: _____ Date _____

giftaid it

For every £1 you donate, A1SLT can reclaim 25p from HMRC - you just need to tick the box below.

- Yes: I want the A1 Steam Locomotive Trust (Charity No 1022834) to reclaim tax on all my donations I make on or after this declaration until I notify them otherwise. I confirm I am a UK taxpayer and understand that if I pay less tax than the amount of gift aid claimed, I am responsible for the difference.

APRIL 2024

Please join **The Valve Gear Club** and help us manufacture and build **David Elliott's final design for P2 class No. 2007, Prince of Wales:**

The target for The Valve Gear Club is £300,000, with supporters making donations of £1000 as a lump sum or in monthly instalments of £100.

We hope to raise the initial £50,000 quickly

to allow for the manufacture of a prototype cam box and test rig, with the intention of the prototype then being fitted to the locomotive. As such we invite you to join 'The Valve Gear Club' today.

Special benefits for members of The Valve Gear Club

- Exclusive Art Deco P2 Poster by Ed Laxton
- Priority to buy a ticket (seat already reserved) on one of the first trains hauled by No. 2007 *Prince of Wales*
- Reasonable access to No. 2007 at all times
- First choice of other components to sponsor
- Opportunity to attend 'The Valve Gear Club Day' when the prototype is tested.



For further information on any aspect of the new Gresley class P2 please visit **www.p2steam.com**, email us on **enquiries@p2steam.com** or call **01325 460163**.
Together we can build this remarkable locomotive!



2007 PRINCE OF WALES

Building Britain's Most Powerful Steam Locomotive